

RAPTOR 55 XP

Production Long Hole rigs

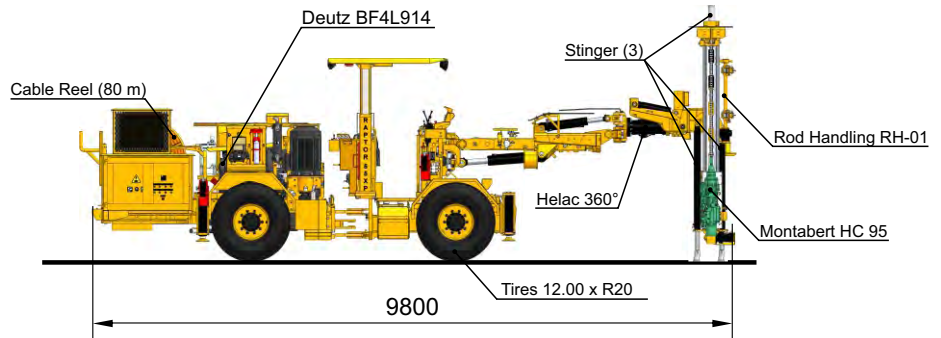
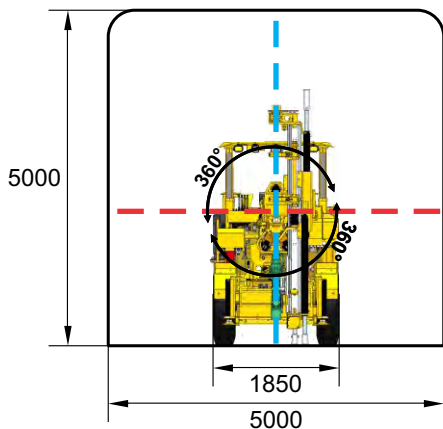

CARRIER

- 4WD Heavy duty carrier, articulated, rear Axle oscillating 15°
- FOPS / ROPS Canopy certified
- Deutz engine BF4L914, 73 kW, air cooled
- Exhaust gas Catalytic Neutralizer
- DANA transmission Power shift T12000 series
- DANA Spicer 112 series axles rear and front
- Service brake oil immersed discs
- Parking brake SAHR
- Electric box Ip64, 575/440/380 volts, 60/50 Hz, Allen Bradley components
- Star delta Slow for main electric motor
- Battery Charger
- Manual fill pump for oil tank
- Four (4) tires 12 x R20
- Four (4) hydraulic jacks
- Cable Reel - 80m
- ANSUL fire suppressor system
- SKF Central Lubrication System, 10 ports
- Cable Reel manual for grease lubrication -pneumatic
- Cable Reel manual for water cleaning

DRILLING SYSTEM

- 1 x HC 95, 22 kW Montabert drifter, equipped with Back Hammering (Extractor)
- 1 x 8000 series Long Hole Feed, total length 3.10m (for 5 FT drill) (Available also for 4 and 6 Ft MF drilling rods, T38, T45 and T51)
- 1 x 5APC Boom model, parallel holding, Helac Unit rotation 360° and 0.80 m boom extension
- 1 x 75 kW Power Pack, ABB motor; Pumps: Bosch Rexroth A10VO100 plus Parker 18gpm
- BARYCENTER SYSTEM which synchronizes both drilling and rotation of the feed axes.
- Parker manual directional valves for drilling control
- Pressure compensated hydraulic system, pumps unloaded at start
- Anti-jamming water pump CR5-90, hydraulic motor driven
- LER7-10 Atlas Copco compressor hydraulic motor driven for drifter lubrication
- SKF Autolube for drifter lubrication
- laser alignment device

DISPLACEMENT

- Horizontal : maximum speed 15kph
- Ramps 15% : maximum speed 6kph

DIMENSIONS

- Width : 1.85 m
- Height : 2.30 m
- Length : 11.35 m
- Weight : 14,500 kg



CAPABILITIES AND APPLICATIONS

- Diameters 51 up to 89 mm, Reaming up to 127 mm, Lengths up to 30 m
- Radial 360° and Fan drilling keeping the Barycenter all the time
- Transverse parallel holding coverage up to 3.00 m
- String R32, T38, T45, T51
- Sub Level, Sub Level Caving and Benching methods
- Productivity up to 15,000 m/month depending on other factors like quality of mining services, water, power, planning, etc.

TRANSVERSE PARALLEL COVERAGE

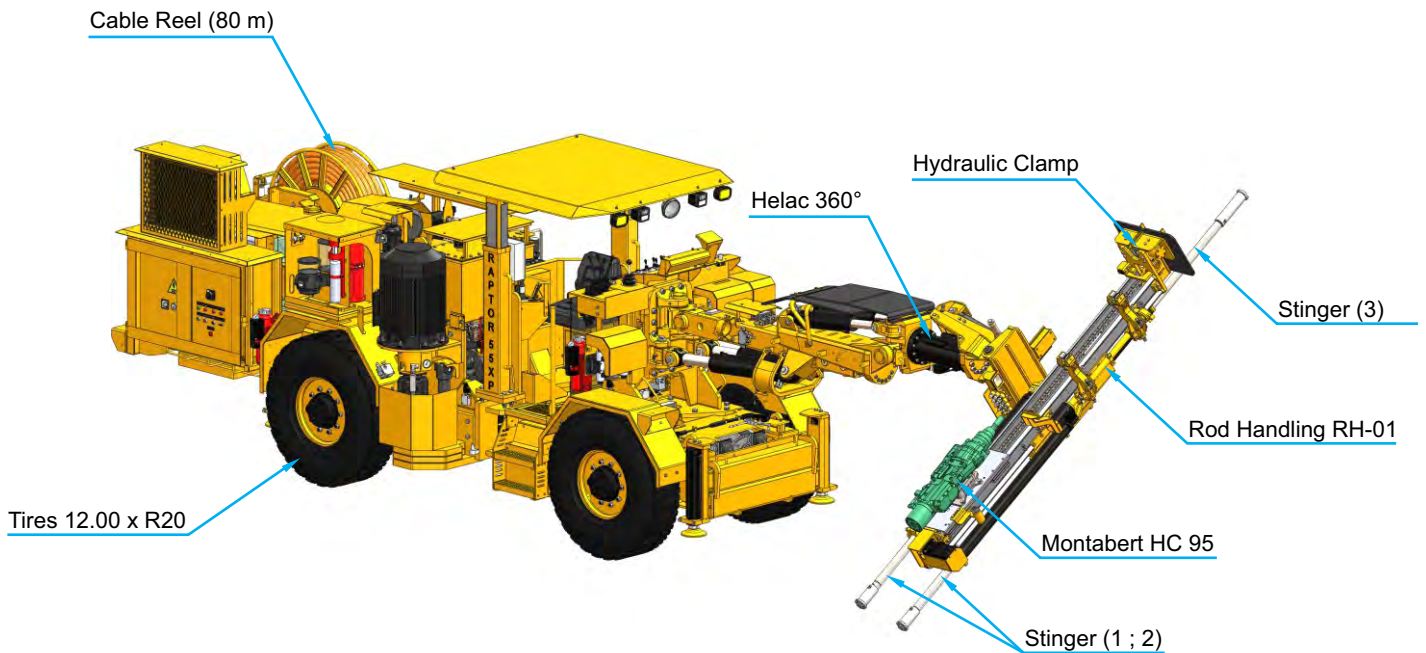
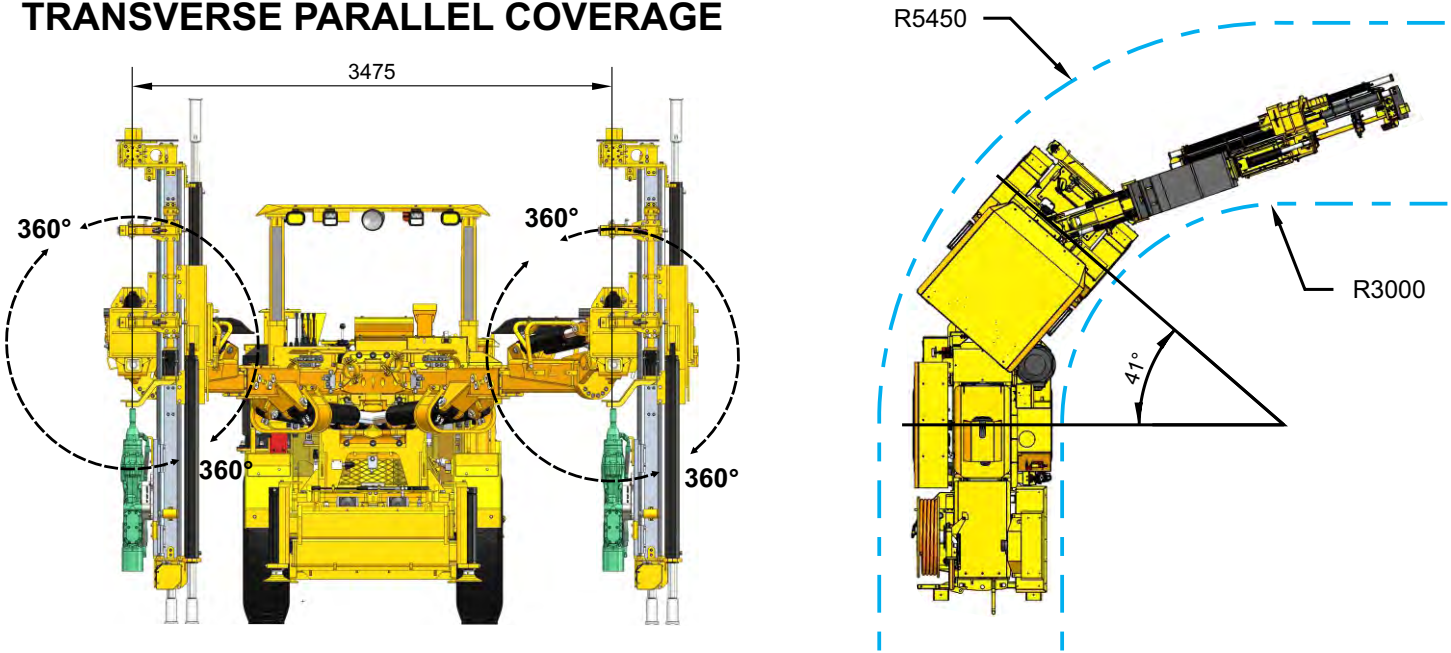

Barycenter System

“Both Drilling Axle and Rotation Axle are synchronized”



OPTIONS:

- ✓ 180 cfm@ 110 psi compressor, for down holes
- ✓ Tropical cooler (Fan oil Cooler), for high temperature sites
- ✓ Dust Collector System, for drilling without water

