

TROIDON 55

Tunneling Jumbo

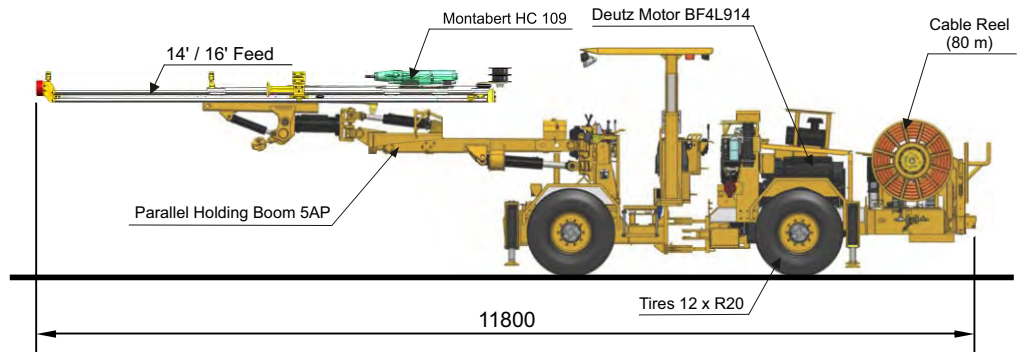
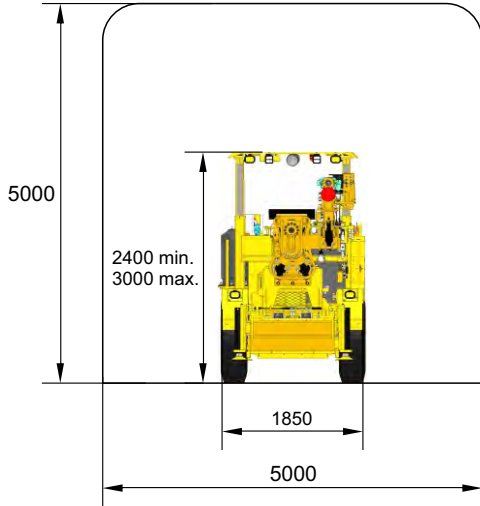

HIGHLIGHTS

- ✓ Tunneling jumbo single boom with parallel holding, sections up to 5.3 x 5.3 m
- ✓ Drilling Feed for 14 ft, option for 16 ft or Telescopic Feed 8 - 14
- ✓ 4WD Heavy duty Carrier , Deutz engine, articulated and rear axle oscillating
- ✓ MONTABERT drifter HC 95 of 22 kW



DRILLING SYSTEM

- 1 x HC 95, 22 kW Montabert drifter, equipped with Back Hammering (Extractor)
- 1 x Standard Feed for 14 feet drill rods
- 1 x 5AP Boom model, parallel holding, Unit rotation 360°, telescopic extension 1.20 m.
- 1 x Power Pack 75 kW , ABB motor; Pumps: Bosch Rexroth A10VO100 plus Parker 18gpm
- Parker manual directional valves for drilling control
- Pressure compensated hydraulic system, pumps unloaded at start
- Anti-jamming function and Rotation Pressure Control Feed
- Reaming bit system valve for feed and RPM control
- Grundfoss Water pump CR5-90, hydraulic motor driven
- LER7-10 Atlas Copco compressor, hydraulic motor driven for drifter lubrication
- SKF Autolube for drifter lubrication

CARRIER

- 4WD Heavy duty carrier, articulated, rear Axle oscillating 15°
- FOPS / ROPS Canopy certified
- Deutz engine BF4L914, 73 kW, air cooled
- Exhaust gas Catalytic Neutralizer
- DANA transmission Power shift T12000 series
- DANA Spicer 112 series axles rear and front
- Service brake oil immersed discs
- Parking brake SAHR
- Electric box IP64, 575/440/380 volts, 60/50 Hz, Allen Bradley components
- Star Delta Slow for main electric motor
- Battery Charger
- Manual fill pump for oil tank
- Four (4) tires 12 x R20
- Four (4) hydraulic jacks
- Cable Reel - 80m
- ANSUL fire suppressor system
- SKF Central Lubrication System, 10 ports
- Cable Reel manual for grease lubrication -pneumatic
- Cable Reel manual for water cleaning

DIMENSIONS

- Width : 1.85 m
- Height : 2.40 m (minimum on transport)
- Length : 11.83 m
- Weight : 14,200 kg

DISPLACEMENT

- Flat Ground : maximum speed 15kph
- Incline 15% : maximum speed 6kph

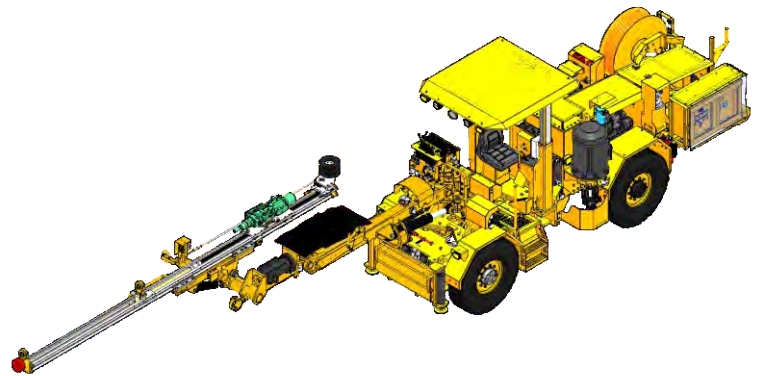

A/C Cabin option



TURNING RADIUS

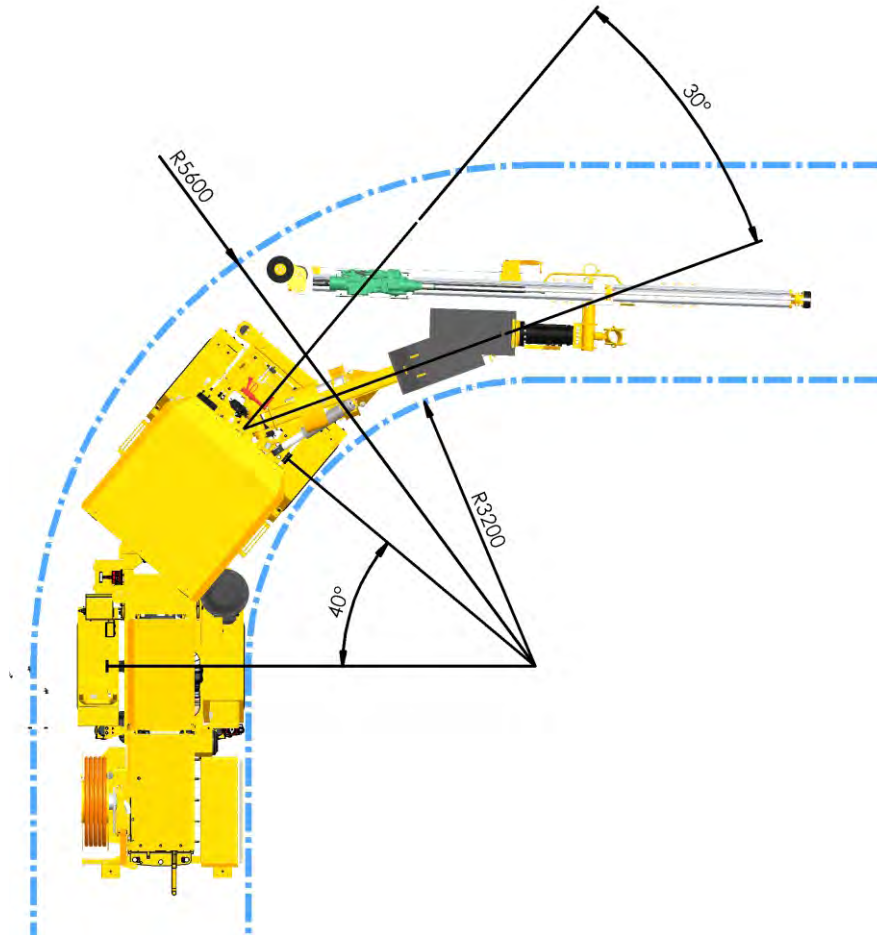

Telescopic Feed option

